

SENSOR - LIQUID SOAP DISPENSER L 109E



148 x 298 x 130 mm

500 ml soap bottle

- Full metal housing in robust, easy-to-clean stainless steel AISI 316L, satin finished, all corners fully welded, tapered front with vertical curved recess.
- EWAR® Sensor - module with drip-free soap pump
- Designed for 500 ml soap bottle, refillable with new screw cap (available from Wagner-EWAR).
- Square perforations to indicate refill level.
- Housing door swings down for refilling.
- Dispenser lockable with cylinder lock.
- Easy to clean due to optimum accessibility.
- Simple mounting: line up with tiles and fasten with 4 screws.



Suggested text for specifications:

Sensor - liquid soap dispenser in stainless steel AISI 316L for surface mounting, satin finish, lockable with cylinder lock. Tapered front with vertical curved recess.

Dimensions 148 x 298 x 130 mm; for 500 ml soap bottles; includes mounting components, batteries and first fill.

Article No. L 109e

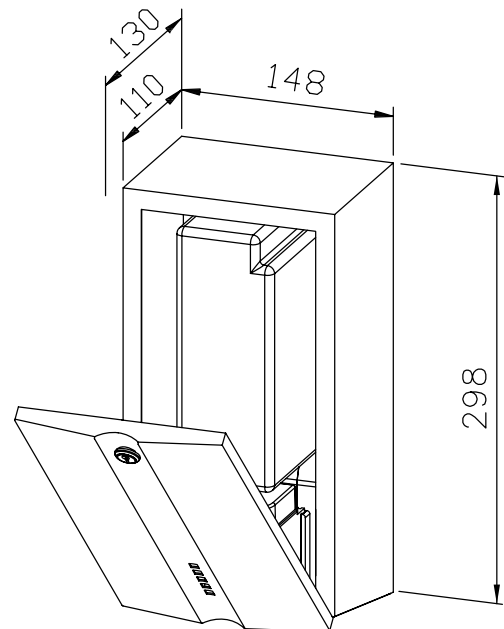

Available surfaces	Ident-No.
satin finished (standard)	828 510
(coloured) plastic powder - coating	829 510

Ernst Wagner GmbH & Co. KG

Ernst-Abbe-Straße 21 · D-72770 Reutlingen · Tel.: +49712151539-0 · Fax: -20
info@wagner-ewar.de · www.wagner-ewar.de